

T5 Engineering VW T5, T6 Side kitchen Assembly Instructions

► www.T5E.co.uk

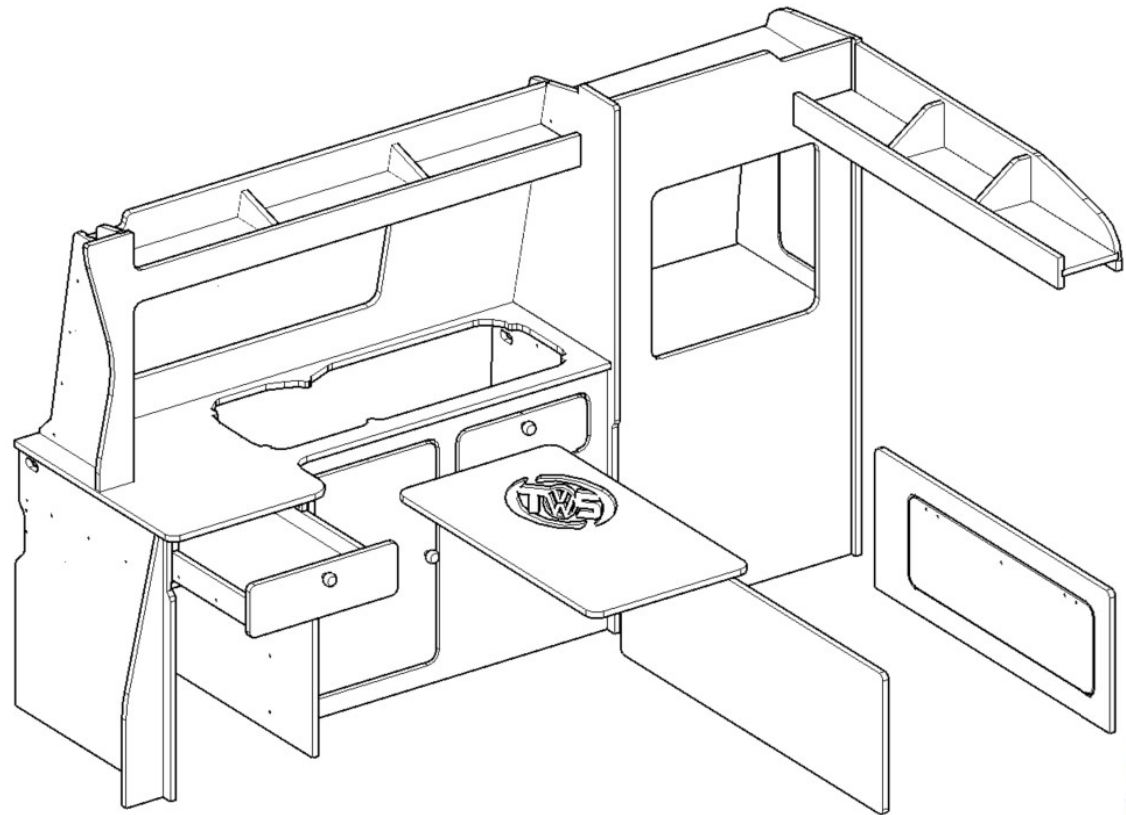

what's Included in your kit

- ▶ 2 sheets of pre-cut white laminate ply wood
- ▶ 1 sheet of pre-cut worktop laminate ply wood
- ▶ 6 sheets of pre-cut pattern laminate ply wood
- ▶ 2 qty small angle brackets
- ▶ 24 qty large angle brackets
- ▶ 200 qty 40x4mm wood screws inc extras
- ▶ 30 qty 25x4mm wood screws inc extras
- ▶ 110 qty 25x3mm wood screws inc extras
- ▶ 25 qty 15mm wood screws inc extras
- ▶ 2 qty piano hinge 345mm long
- ▶ 1 qty piano hinge 300mm long
- ▶ 1 qty piano hinge 470mm long
- ▶ 1 qty piano hinge 700mm long
- ▶ 50m of knock on edging (some extra)
- ▶ 2 qty Magnets 42mm
- ▶ 12 qty Magnets 62mm
- ▶ 1 qty 100mm x 30mm x 3mm biscuit joint board
- ▶ 6 qty door knobs



Large angle
Brackets

Small angle
Brackets for
Drawer only



40x4mm screw
For joins into
edge of ply
board

24x4mm screw
For joins into
face of ply
board

25x3mm
screw for
piano hinge
and fixing
the plastic
magnet
blocks

15x3mm screw for
fixing the angle
brackets and
brass magnet
strips

what's Included

QTY 6 PRE-CUT PATTERN BOARD

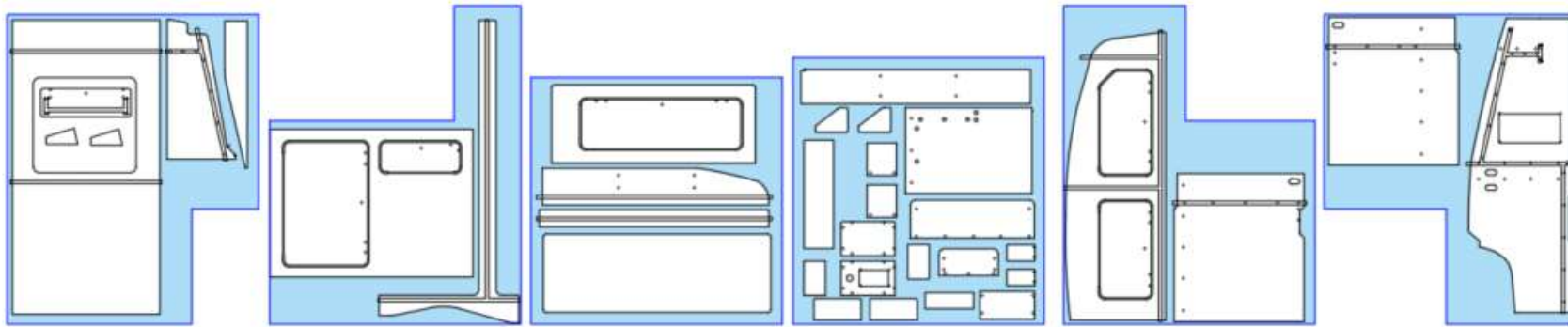

QTY 1 WORK-TOP BOARD

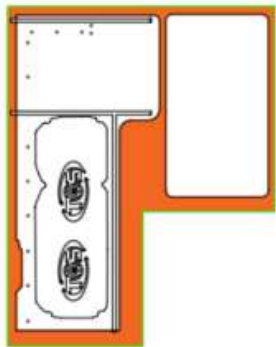

QTY 2 WHITE BOARD

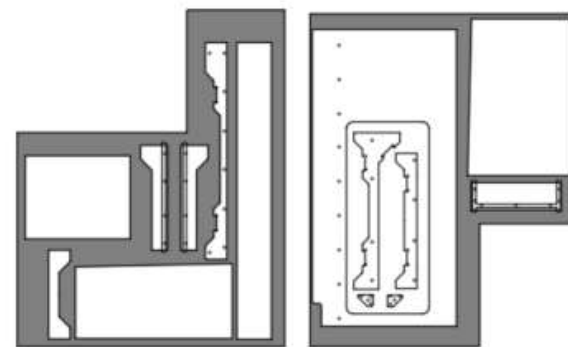

What you will need

- ▶ Battery screw driver
- ▶ Hand screw drivers
- ▶ sand paper
- ▶ Wood glue
- ▶ Electric Router
- ▶ “T” slotting cutter bit. (3mm width cut, 9.5mm cut depth) with guide wheel. Available from Morland UK
- ▶ Masking tape
- ▶ Nylon or wood mallet (small)
- ▶ Hand saw
- ▶ Jig saw
- ▶ Craft or Stanley knife
- ▶ Carpenters hand clamps/ grips
- ▶ Tape measure
- ▶ Carpenters Square
- ▶ Smev 9222D sink hob (gas on the left, taps on the right)
- ▶ Table leg or rail support
- ▶ Tambour door (optional)



Preparation

- ▶ Create a clear flat work area to assemble the kit
- ▶ Do not assemble on concrete or uneven abrasive surfaces that will scratch the panels
- ▶ Unpack the pre cut sheets and carefully remove them one at a time
- ▶ Use the “what's included” list on the second page to ensure you have received all parts needed
- ▶ Inspect the sheets for damage that may have occurred during transport. If any damage has occurred notify T5 Engineering before removing any of the location tabs. Damaged parts that have been removed from the outer stencil via cutting the location tabs may not be replaced free of charge by the carrier. Damage around the outer stencil won't affect the kitchen, its only there to protect the inner kitchen parts during transport.
- ▶ Use a fine saw or craft knife to cut the location tabs and free each part of the outer stencil. Take care to not scratch the surface of the laminate. If you're using a jig saw, use a fine blade and ensure that the surface of the material is protected with masking tape so it wont scratch the surface of the laminate





T5 Engineering VW T5 or T6 Side Kitchen Assembly Instructions

Preparation

- ▶ Use sand paper or a wood file to reduce the remains of the tab down to the surrounding profile of the part. When sanding be careful not to splinter the laminate away from the wood that will be visible on the finished part. It is critical that these tabs are removed completely as they will affect the fit of the assembly when it comes to gluing the recesses together
- ▶ Use the sand paper to carefully remove any residual wood fibres around the edge of the part
- ▶ Make a sanding block from a thin piece of board wrapped in sand paper to clean any residual wood fibres from the corners of the recesses
- ▶ Take the time to ensure you have removed all tab stubs and residual wood fibres. Poor preparation will show in the finished assembly
- ▶ Repeat the process on all parts and lay them out where you can visibly identify them as you go through the build process
- ▶ Don't discard the outer stencil until the build is complete. It can be used for making packers and it will be needed as a test piece for setting up the slotting cutter in the router to cut central to the panel

T5 Engineering VW T5 or T6 Side kitchen Assembly Instructions **Assembly**

- ▶ Identify the below parts. These are taken from the pattern board only
- ▶ The edges shown in Blue are the edges that require slotting with the router ready for the knock on edging. Use a pencil or masking tape to identify the edges shown in blue on the panels themselves
- ▶ Every door and door frame has a raised edge to help you position the hinges correctly. Ensure you don't rout a slot into this raised surface as it will remove the material needed to screw and fix the hinges correctly
- ▶ All slotting can be completed but don't install the knock on edging at this stage. It may become damaged and marked while assembling the rest of the kitchen and the wood clamps will deform it unevenly.



Don't slot this raised edge on any door or door frame

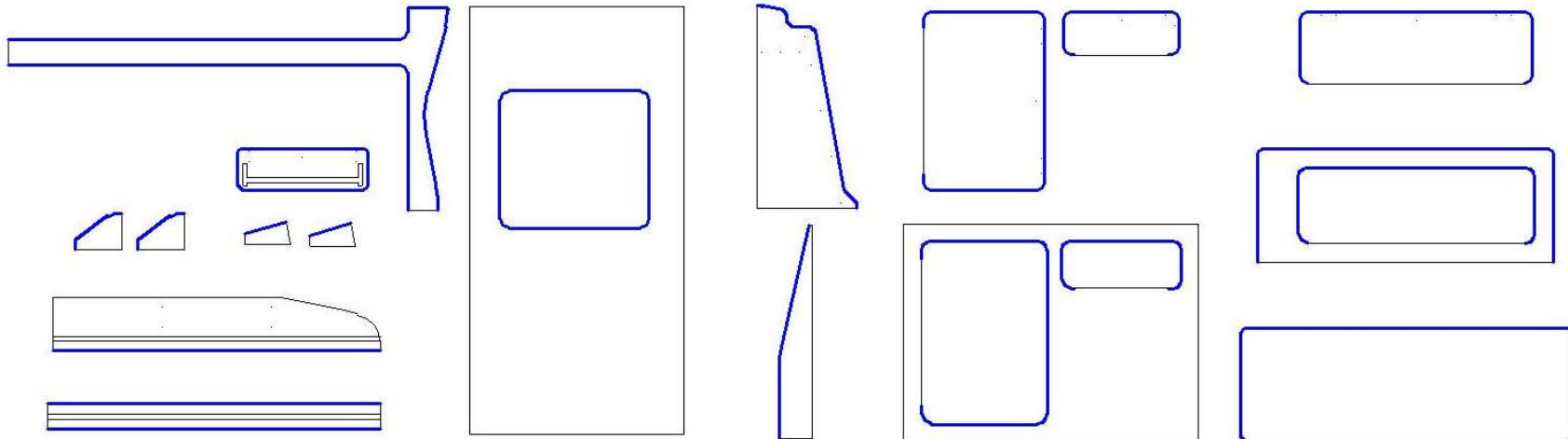
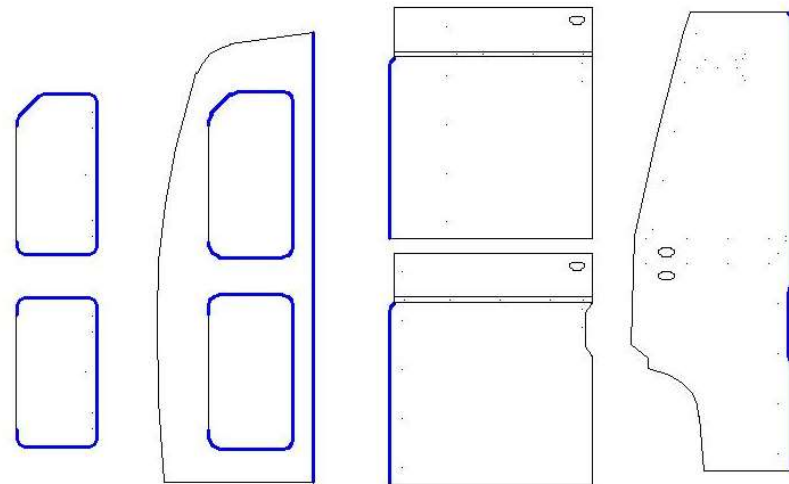

T5 Engineering VW T5 or T6 Side Kitchen Assembly Instructions

Assembly

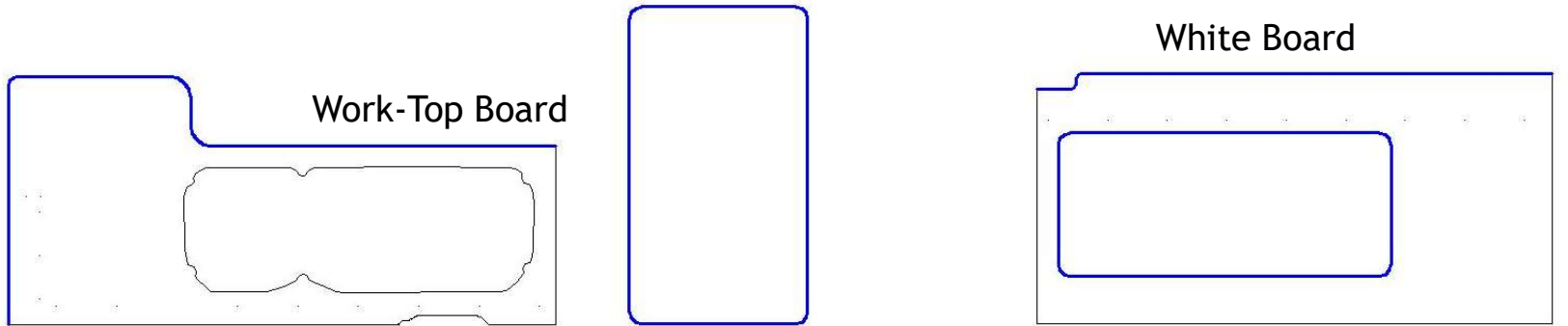

- ▶ Identify the above parts. These are taken from the work-top and white board only
- ▶ When setting up the slotting tool in the router it is crucial to ensure that the center of the cutter is central to the 15mm board. Before slotting any of the finished panels take the time to practice on a piece of the waste outer stencil and finely adjust the height setting on your router to get it precisely central. Failure to set the router depth correctly will result in the edging leaving one edge of the panel exposed and overhanging the opposite edge. As shown below



CORRECT

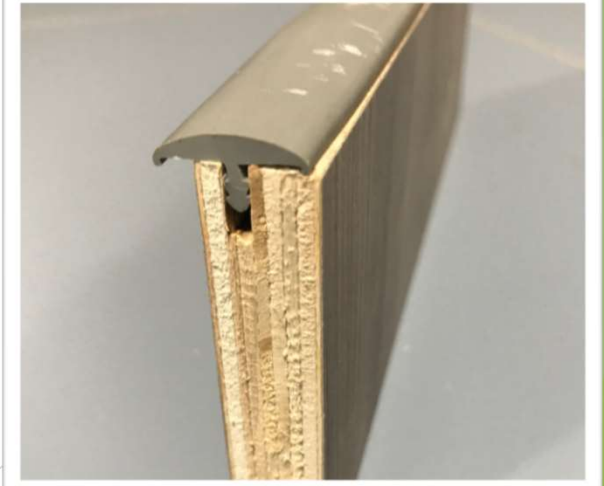

INCORRECT

T5 Engineering VW T5 or T6 Side Kitchen Assembly Instructions

Assembly

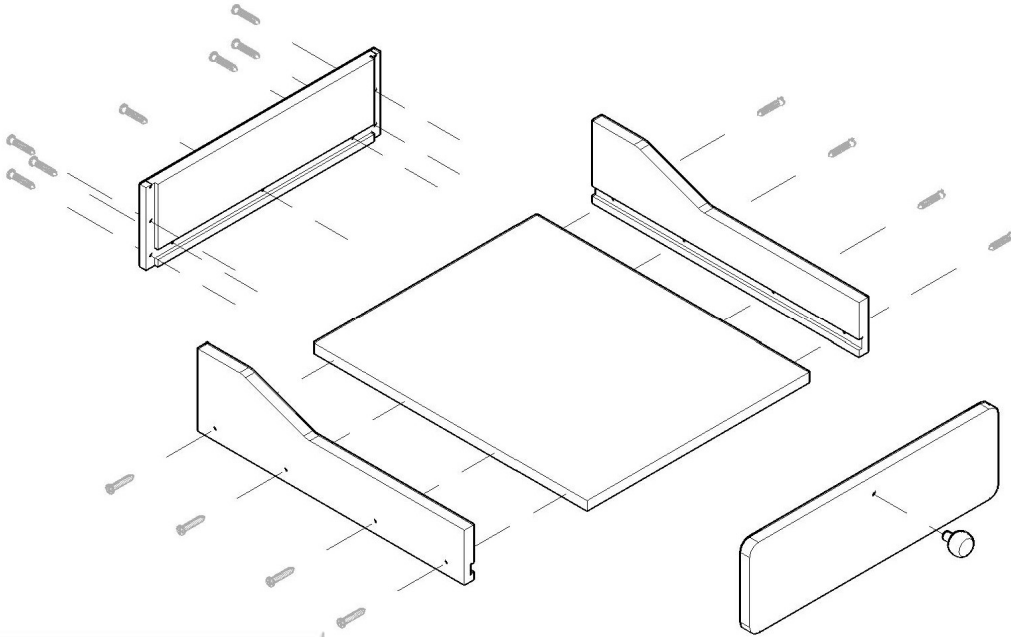

- ▶ Identify the parts shown to assemble the drawer
- ▶ Apply a layer of wood glue to the recessed edges
- ▶ Assemble the base, sides and back of the drawer installing the 40mm wood screws
- ▶ Install the drawer face and use wood clamps to firmly hold the drawer face onto the assembly. Use off cuts of the outer stencil to protect the surface of the panel from the clamps. Don't over tighten the clamps to the point that the drawer deforms
- ▶ Use a cloth to wipe away any excess glue
- ▶ Allow the wood glue to dry before installing the 42mm magnet strips into the pre drilled holes and the right angle braces. Use a hand screw driver to install the 15mm magnet screws. use the 15mm screws for the small angle braces. The screw holes for the angle braces are not pre-drilled
- ▶ Use the threaded screw provided to fit the door knob. use a hack saw to reduce the length of the screw down to suit 15mm board. Tighten the door knob by hand only.

Assembly

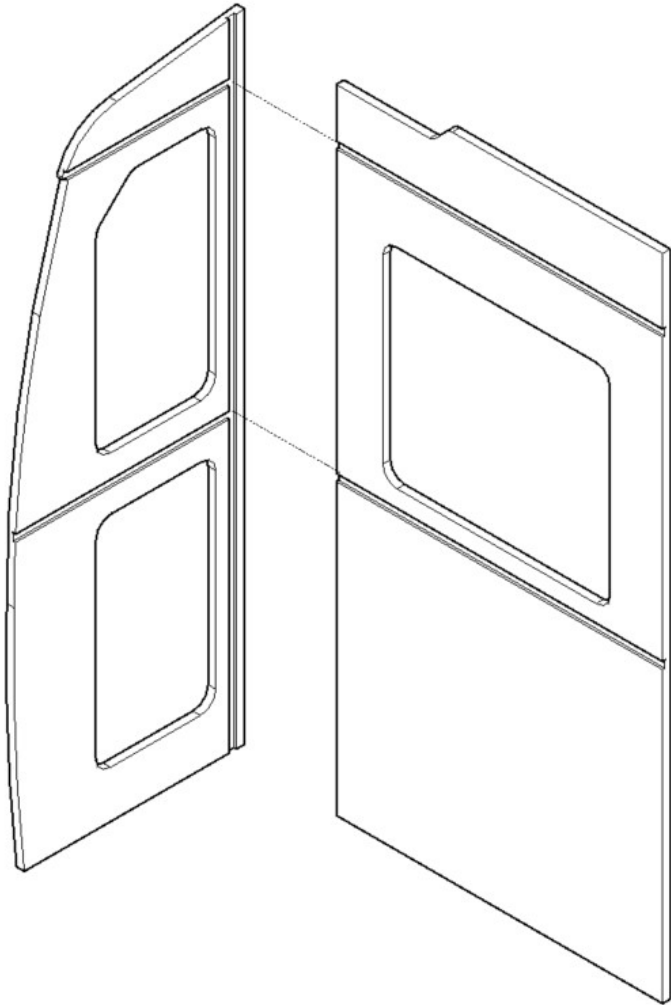

- ▶ Identify the parts displayed
- ▶ Apply a layer of glue to the recessed edges
- ▶ Place the wardrobe front and the end door section on a flat surface and marry the recessed edges together. Ensure that the two are perfectly flush on the bottom edge and use wood clamps to lightly pinch them together
- ▶ Take the larger of the two white shelves and identify which end measures 450mm, take the opposite end and marry it into the end door section for the bottom shelf as shown
- ▶ Take the smaller of the two shelves and identify which end measures 315mm, take the opposite end and marry it into the end door section for the bottom shelf as shown
- ▶ Use wood clamps to lightly pinch all glued recessed edges together and wait for the glue to dry
- ▶ Use a cloth to wipe away any excess glue
- ▶ Once dry remove the clamps and install two of the large angle braces using the 15mm screws on the underside of each of the shelves, adjacent to the outer edges of the vertical panels. The angle braces have not been pre drilled
- ▶ The window and door openings can now have the knock on edging applied. Forward to page 14 For tips on installing the knock on edge.

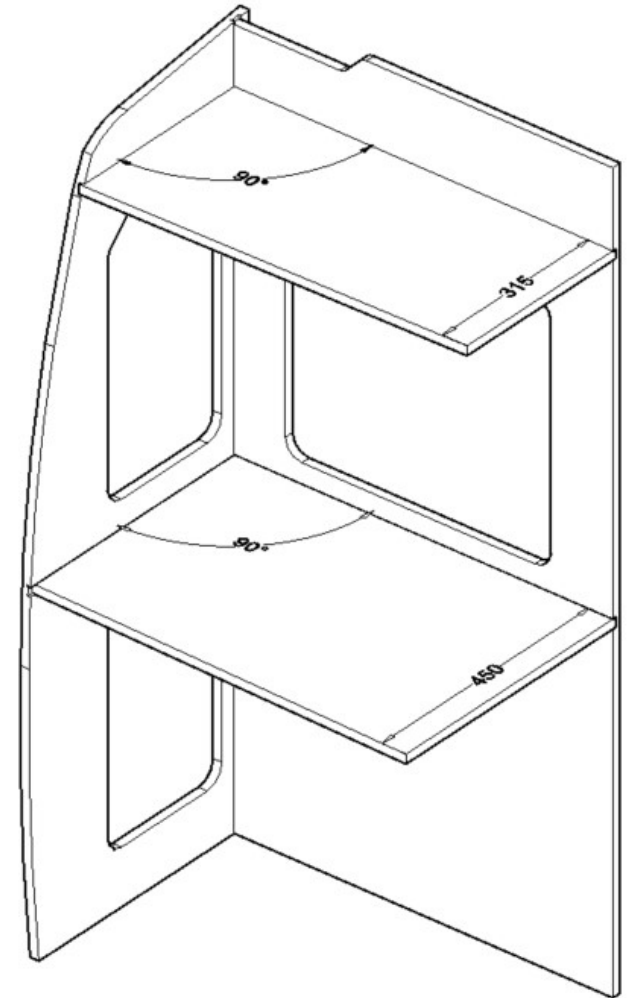

Assembly

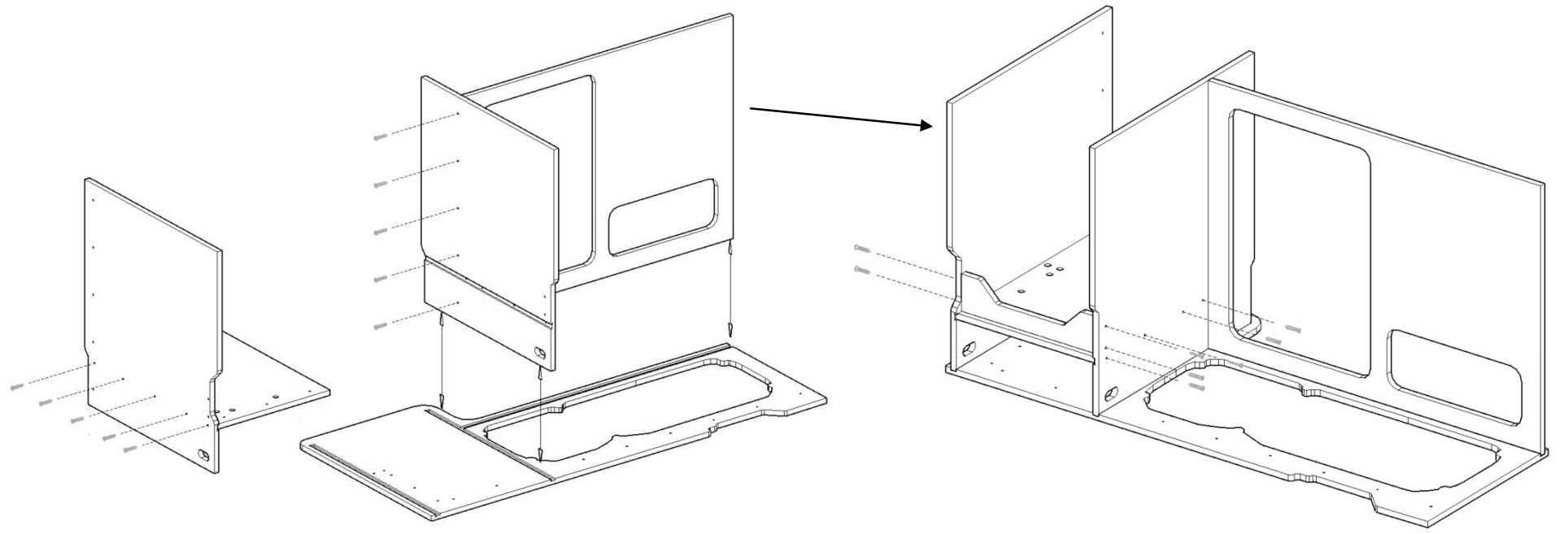

- ▶ Identify the parts displayed
- ▶ Apply a layer of glue to the recessed edges
- ▶ Place the worktop surface upside down so the recess is pointing up. Position the kitchen front and the inner fridge housing into the recess as shown, and gently knock them down in to the depth of the recess. Ensure that the larger door opening is closest to the fridge housing as shown.
- ▶ Use the 40mm screws to fix the panels together. There is no recess for the kitchen front to marry the fridge housing so use a set square and visually check that it is central to the screw holes before fixing. Ensure that for both sides of the fridge housing panels, that the recess is pointing inward and that the wiring and hose cut out openings are at the back
- ▶ Take the opposing fridge housing panel and position the flat shelf support into the recess then fix with the 40mm screws. Check that the larger holes in this shelf are located directly above the holes pre-drilled in the work-top board as these will need to line up when you fix the upper splash-back board
- ▶ Take the stiffener board and fix to the fridge housing panels and the drawer support shelf.
- ▶ Marry the two assemblies together and finish installing the screws as shown

Assembly

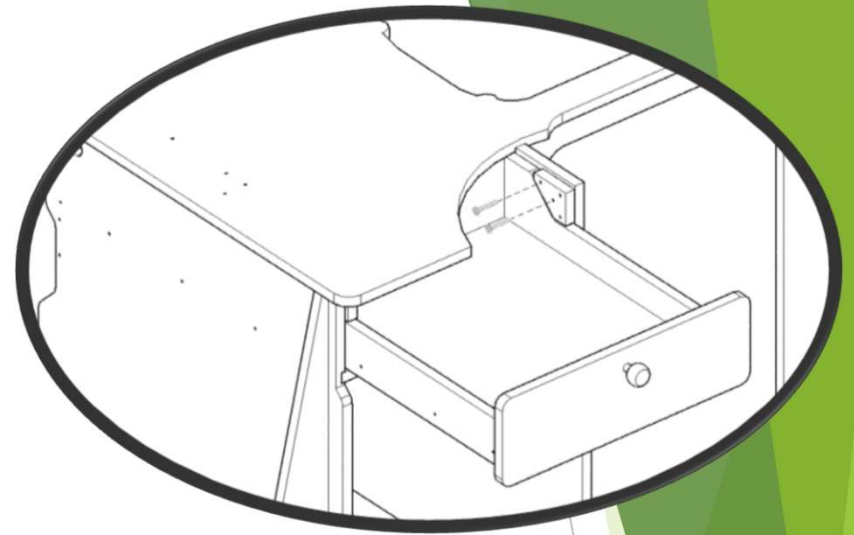
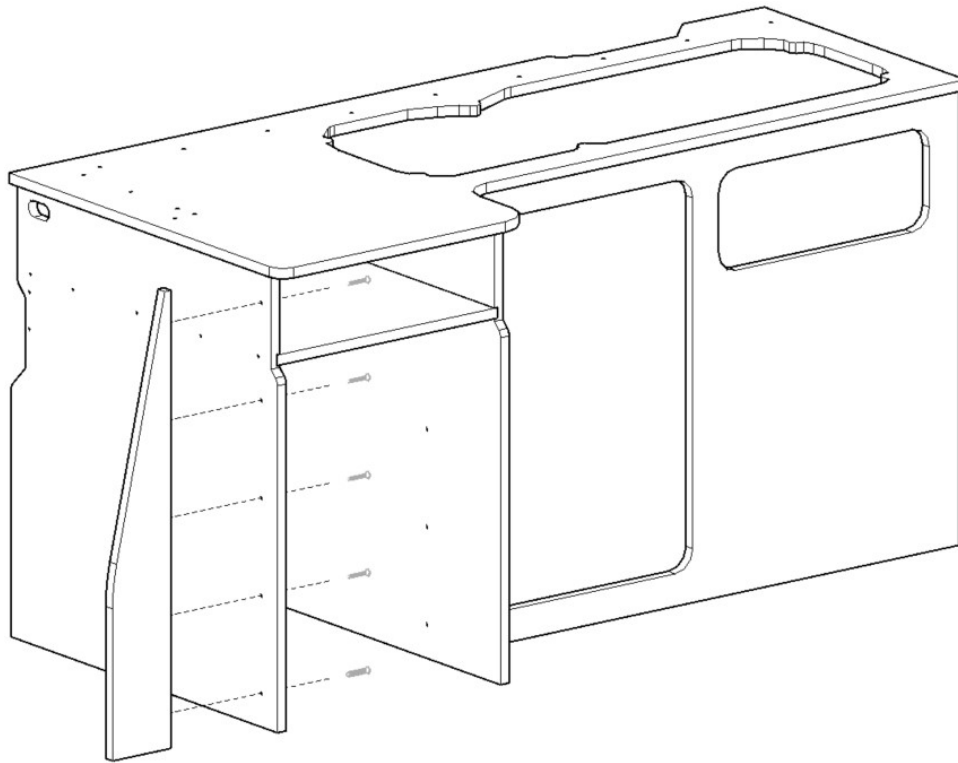

- ▶ Very carefully lift the entire assembly with two people and place it the right way up. Use clamps to pinch the work-top surface to the kitchen front and drawer support shelf use a cloth to wipe away any excess glue and leave the glue to dry
- ▶ Once the glue has dried, use three angle braces and 15mm screws to fix the worktop to the kitchen front and the inner fridge housing (pilot holes not drilled)
- ▶ Fix the vertical pelmet using the screws as shown above. You shall need to do this before installing the drawer. Use the 40mm screws for the lower 4 fixings and use a 25x4mm for the top fixing.
- ▶ Fix the magnet mounting blocks to both sides of the fridge housing using the 3 x 25mm screws. You will need to put the drawer in place to do this as the mounting blocks also retain the drawer. Keep the face of the mounting block flush against the front and touching the underside of the work-top.
- ▶ Use the 42mm magnets and fix them to the pre drilled mounting blocks. First fix them so they can slide freely on the screw and take the time to position them so the drawer completely shuts at the point the magnet contacts. If the magnet is set too far back it will not retain the drawer properly.

Assembly

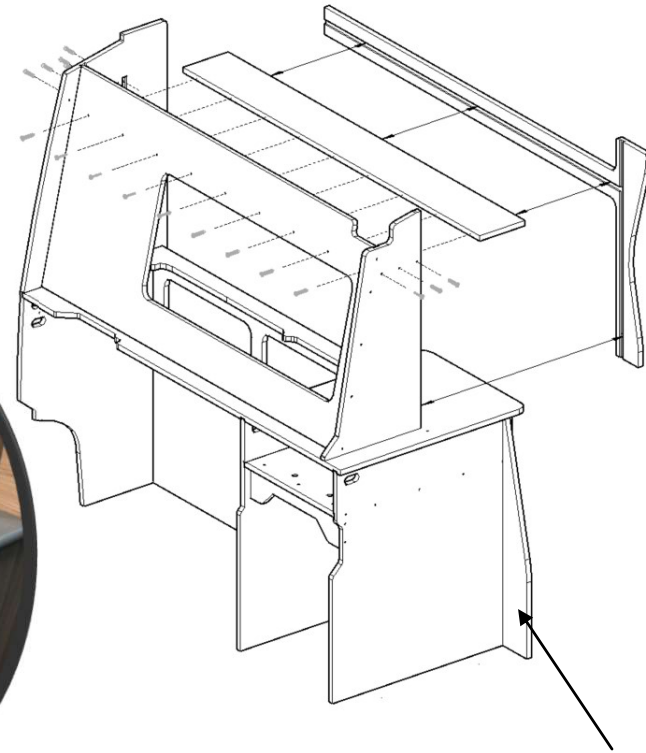
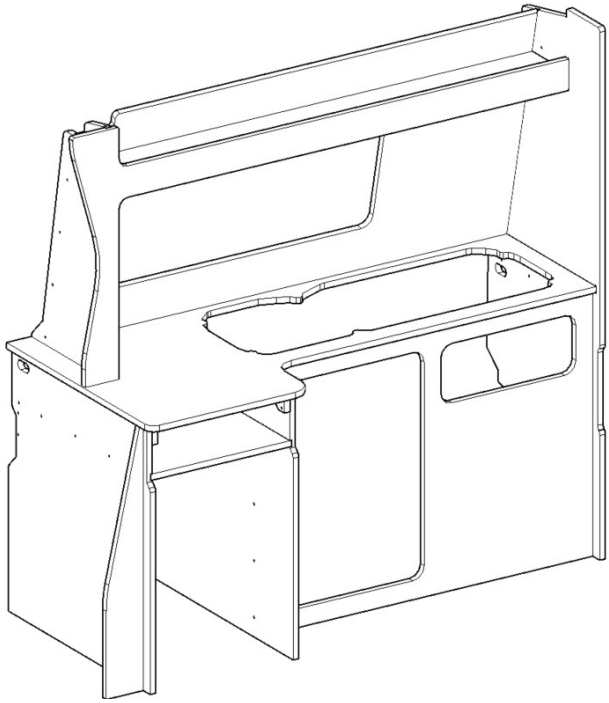

- ▶ Identify the parts displayed
- ▶ Apply a layer of glue to the recessed edges
- ▶ First fix the wardrobe side to the work-top and kitchen front using the 40mm screws
- ▶ Fit the splash back board into the recess and screw through the wardrobe wall but don't screw it down to the worktop
- ▶ Fix the shelf and the end cap to the splash back board and ensure that the end cap is exactly flush with the back edge of the worktop before screwing (as shown in the photo). If not completely flush then the pre drilled screw holes will miss. Now you can finish fixing the worktop to the splash back. You will need a screw driver extension or a long handled screw driver to catch the screws within the drawer compartment
- ▶ Next take the shelf and put it into the recess on the wardrobe and end cap board. Before screwing in place put the "T" fascia board onto the front of the shelf and ensure they all fit into the recess provided. Occasionally the shelf will need a slight sanding down to make it fit. Before screwing in from the back of the board check that the shelf isn't sagging down in the middle as it is only supported from the recesses at either end.
- ▶ Clamp the "T" fascia to the shelf front lightly and leave until the glue sets.

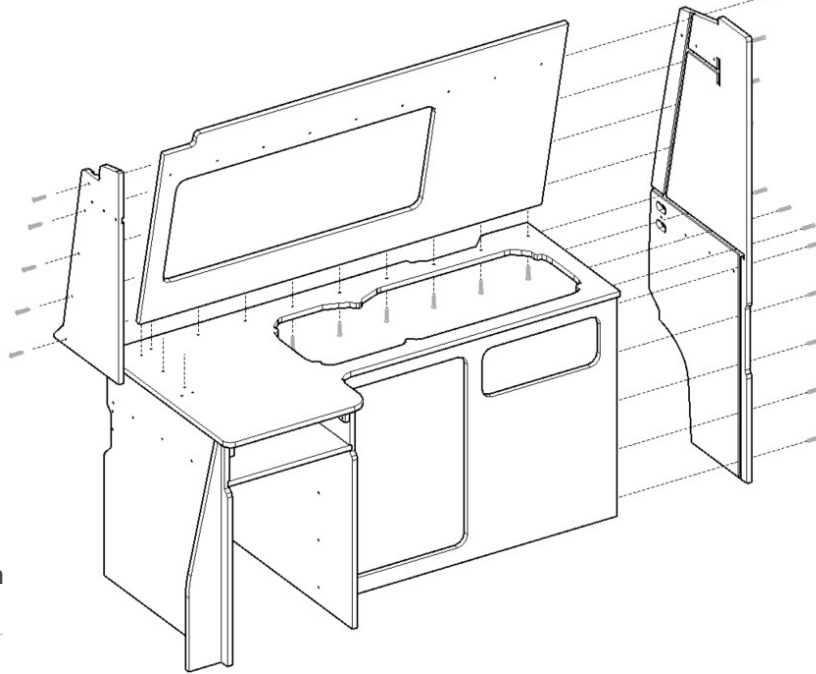

Assembly

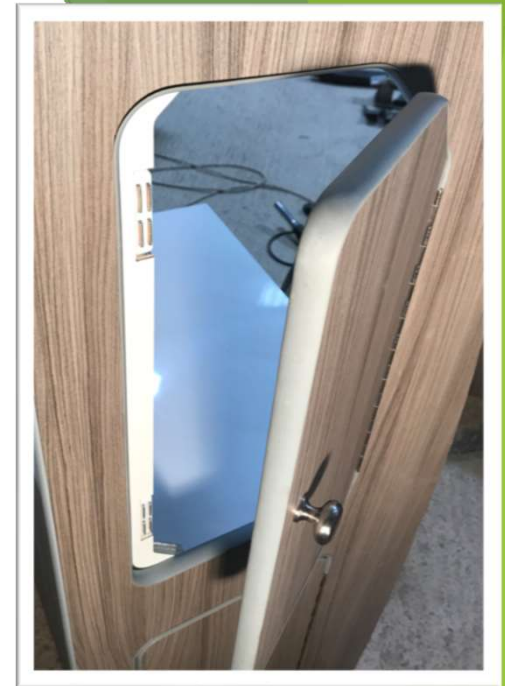

- ▶ Now that the two main assemblies are together we can complete the knock on edging.
- ▶ Using a flexible tape measure record the lengths of edging and add on a small amount over overlap to trim in situ.
- ▶ For both internal and external corners it is necessary to notch out the tongue of the knock on edging so that it can contour around the tight radiuses. This can be done with a craft knife or snips. Take the edging and snip out three small triangles as shown.
- ▶ Use a wooden dolly or soft mallet to gently tap the edging into the recesses. Don't use a steel hammer or anything sharp that will mark the edging.
- ▶ For doors try to get the joint of the edging along the bottom where it cant be seen. For door openings try to get the joint along the top for the same reason.
- ▶ Where the edging meets an end or overlaps itself, snip 5mm of the tongue off at the end so that they butt up neatly
- ▶ Make sure that the edging follows the edge of the wood neatly all the way. Any deviation will prevent the doors from closing properly.

Assembly

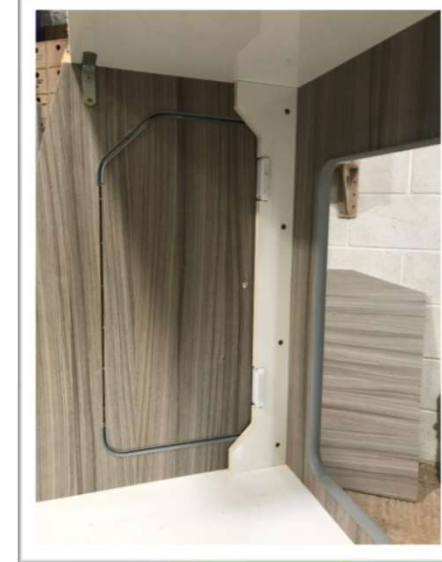
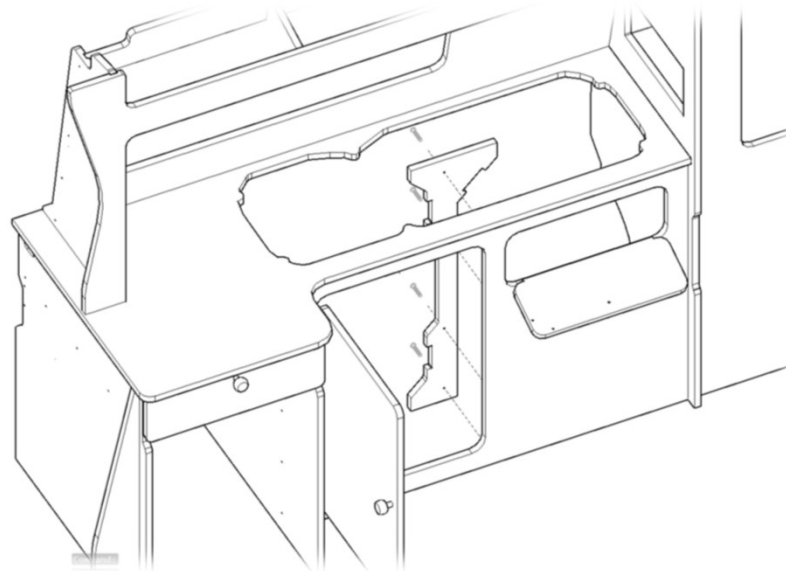

- ▶ To install the hinges, first line up the pre-cut piano hinge with the matching raised surface along the back of the door and door opening. Back fold the hinge over the door and check that the hinge sits perfectly on the raised edge to ensure that the door opens centrally. Check that you screw the hinge on the right way around, The doors will all have holes pre drilled into the inside to take the magnet strips.
- ▶ Fix the magnet strips to the inside of the doors using the 15mm screws in the pre drilled holes and don't overtighten them.
- ▶ Hang the door in the door opening on two screws only, check it can close centrally before installing the remaining screws. There is some play in the screw holes and it can be fiddly the first time! check that the door has the same gap all the way around and that the edging does not contact. A small amount of contact in the edging will wear in after time as long as the door can be closed flush without using force.
- ▶ Fix the plastic magnet blocks to the door stops in the pre cut slots provided using the 25x3 mm screws. Fix them loosely so that the magnet can still slide on the screws.
- ▶ Take the door stops with the magnet blocks semi fastened and position on the inside of the door frame. Each door stop has a set place so familiarize yourself with which is which. Use the 25x4 mm screws to fix the door stops in position. The door stop edge should sit flush with the edge of the door frame however the edging can sometimes obstruct it slightly. Take the time to position the door stop and check it against the magnet strips before screwing it in.
- ▶ When the door stops are in position, close the door and push the loose magnet against the magnet strip, then tighten the magnet strip to prevent the magnet from moving.
- ▶ A correctly hung door should be able to close and remain closed with a gentle push. Slamming the door will usually bounce it back off the magnet



Assembly

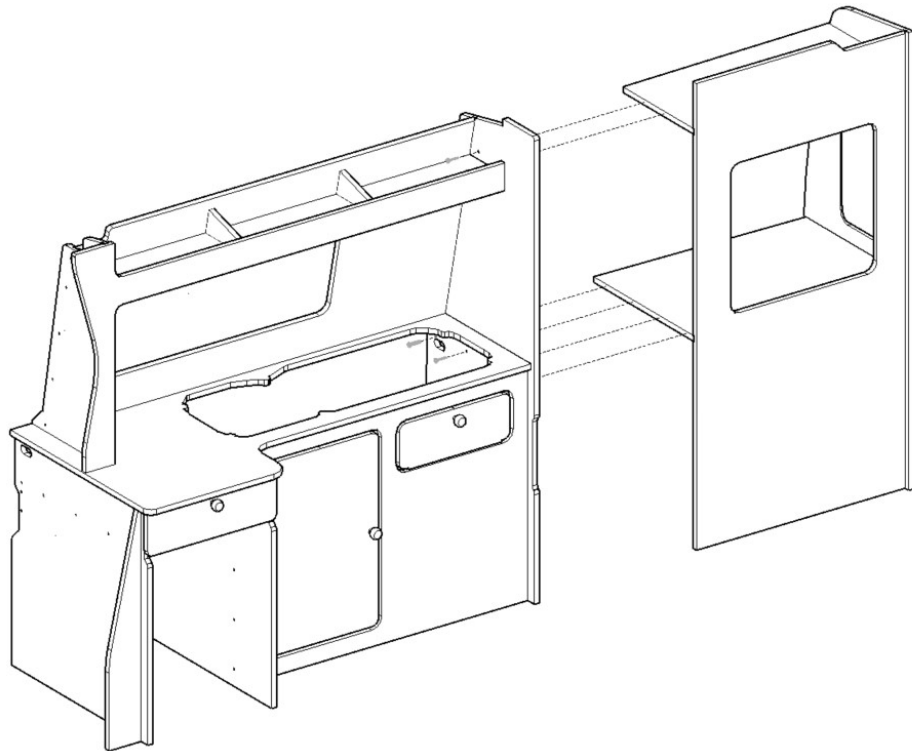

- ▶ Take the two assemblies and put them into the van. The dividing wall of the wardrobe, and the wardrobe front have been left overlong so they can be scribed and fitted to a variety of pop top or normal roof. Mark the elevation of the roof and trim away at the panels until they can be pushed back in where they touch the van lining panels.
- ▶ Once you have them fitted take a measurement against the edge of the kitchen to the opposite wheel arch and check that your rock and roll bed will fit. You may need to trim more away from the back edge of the kitchen if you have a slightly oversized bed or lining panels.
- ▶ Bring the two assemblies together and use the 40mm screws to fasten the wardrobe to the kitchen assembly through the dividing wall into the shelves and wardrobe front. Use 4 large angle brackets and fix them to the under side of the shelves and the dividing wall using the 15x4mm screws (not pre-drilled).

Assembly

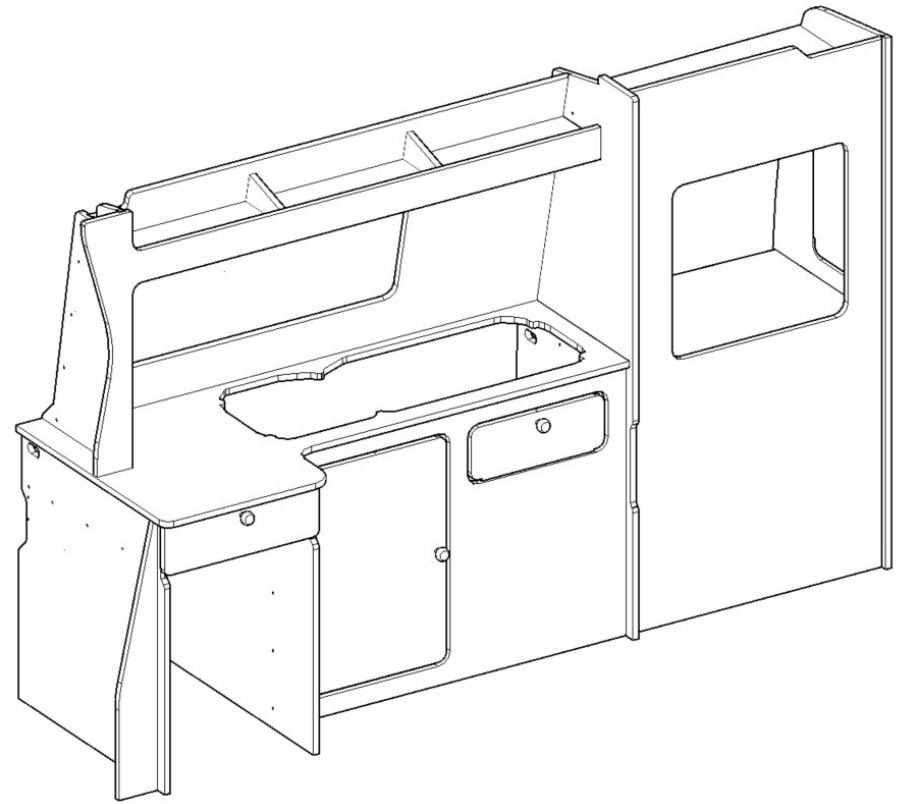
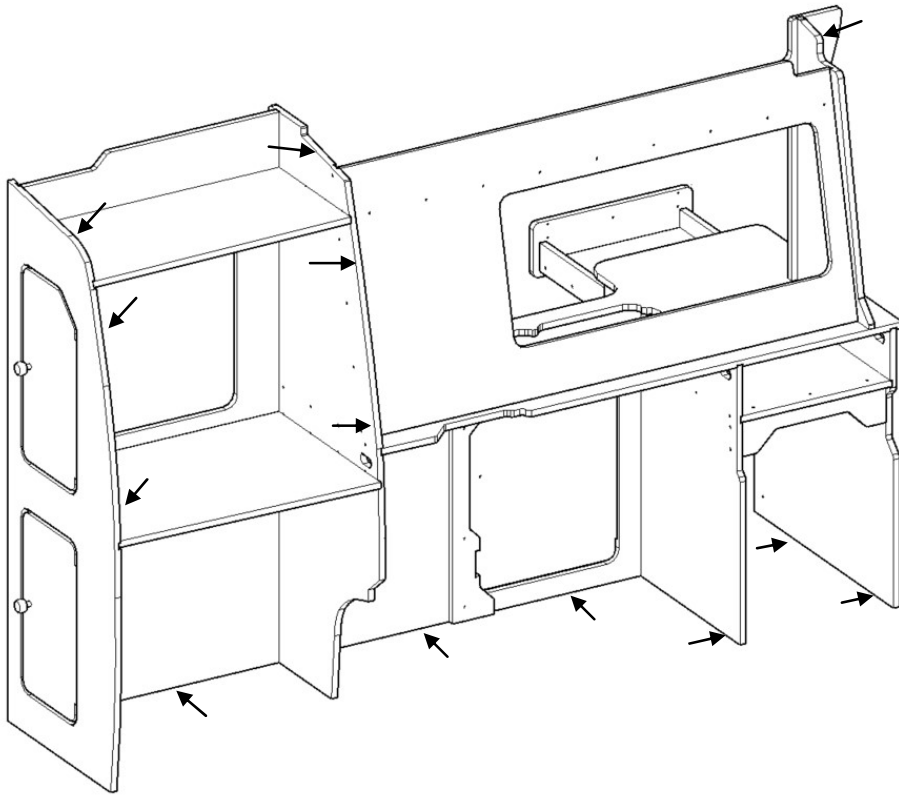

- ▶ Use the large angle brackets and the 15mm screws to fasten the kitchen assembly to the van lining panels. The screws to fix the lining panels have not been provided. Their size will depend on the thickness and material of the lining panels. If possible to connect to exposed van steel work we recommend using tech screws
- ▶ We don't pre-drill the angle brackets because there is no set rule where to position them in your van. The arrows above indicate ideal positioning for them but this may conflict with your lining panels or electrical system.
- ▶ Wherever possible try to ensure there is something between the bracket and the steel structure of the vehicle to prevent squeaking as the van travels. This can be carpet or rubber.



T5 Engineering VW T5 or T6 Side kitchen Assembly Instructions

Assembly

Set back from the Floor to compensate For the wardrobe edge

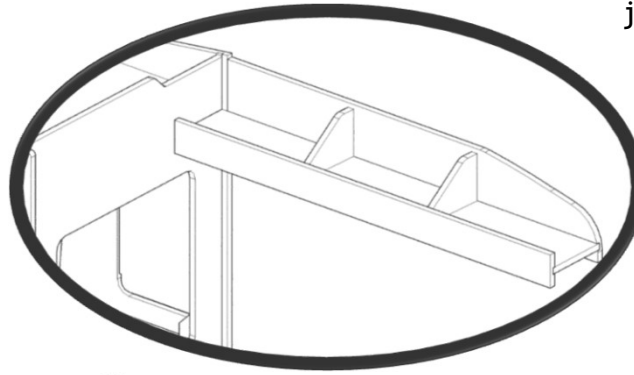
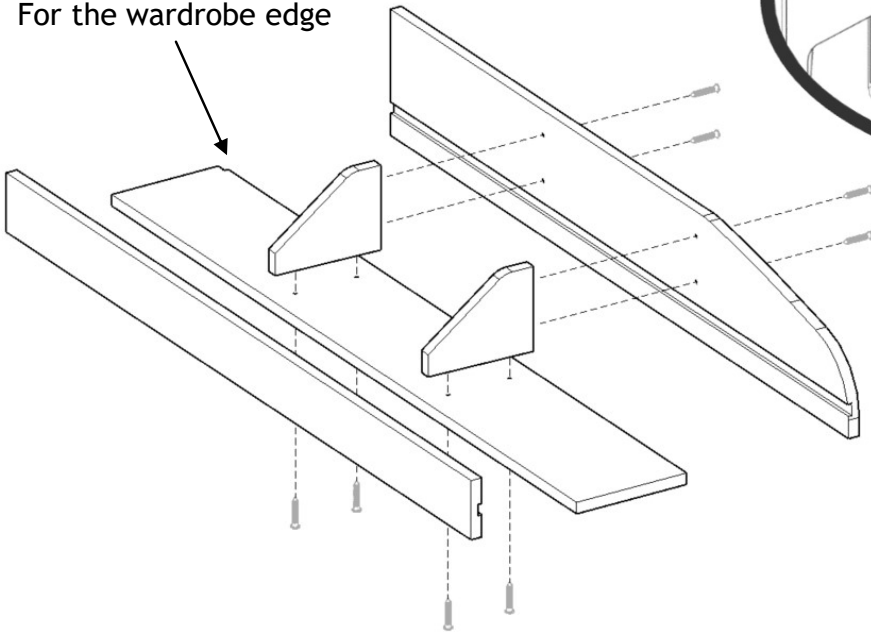

3mm biscuit joint



- ▶ Identify the parts required for the rear van shelf. Firstly take the back panel and scribe against the van wall with the kitchen assembly already installed in the van. The back board of the shelf should sit inline with the wardrobe panel containing the two doors and it should be touching the soffit of the van roof. The shelf floor and front should be offset to compensate for the difference between the wardrobe front and the wardrobe door panel.
- ▶ Once scribed and trimmed, apply a layer of glue to the recessed edges and marry them to the shelf base. Insert the shelf dividers and align them with the pre-drilled holes. Use the 40mm screws to fasten the shelf back and base to the triangular dividers. Use wood clamps to secure the shelf front to the shelf bottom until the glue has dried.
- ▶ When installing the shelf use the 3mm ply biscuit joint and glue it into the edging rebate on both the wardrobe and the shelf back. This will prevent misalignment with the wardrobe.
- ▶ Take the pre drilled wooden blocks shown right. These fix to the wardrobe wall and opposite van wall. The larger sits inside the shelf and the smaller site in the rebate beneath the shelf. You may wish to edge them or carpet them for aesthetics. They will need to be trimmed down to fit after carpeting.

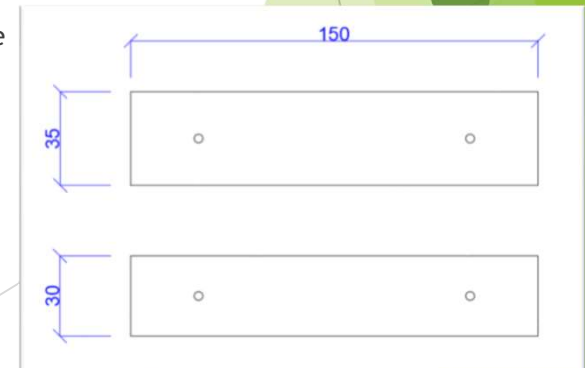

T5 Engineering VW T5 or T6 Side Kitchen Assembly Instructions

Assembly

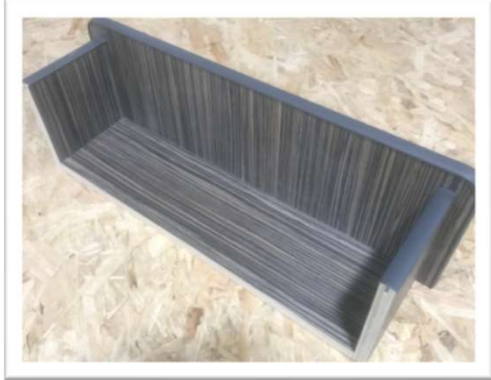

Tambour door enclosure



Plug socket
Mount

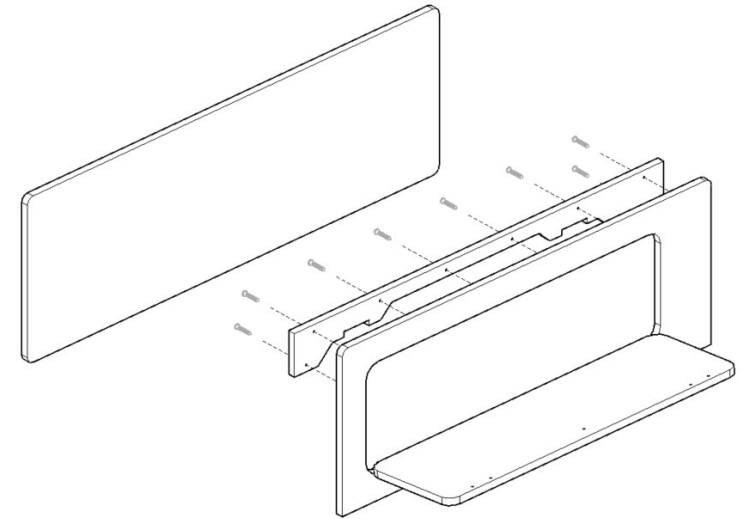

Front and rear bed boards



Gas bottle
holder

- ▶ Take the bed board and install the piano hinge, magnet strips, magnet blocks and magnets in the same manner as the kitchen doors. There is a second bed board provided without a door. Its recommended to use the bed board without the door for the front because the bed release handle wont conflict with the door. However you can put them whichever way around you like. The bed board will need to be cut to fit your bed. Fastening the bed board to your bed will depend on the bed design itself. Fixings to attached the bed board are not included.
- ▶ The table is included in the kit. The table can be installed either via the rail and fold down leg system or by a free standing leg that slots into a low profile receptacle on the van floor. Table leg and fastening system are not included.
- ▶ Also included in the kit are the optional tambour door enclosure, internal wardrobe plug socket mount, and small gas bottle holder. As pictured



T5 Engineering VW T5 or T6 Side Kitchen Assembly Instructions

